

Operator's Manual

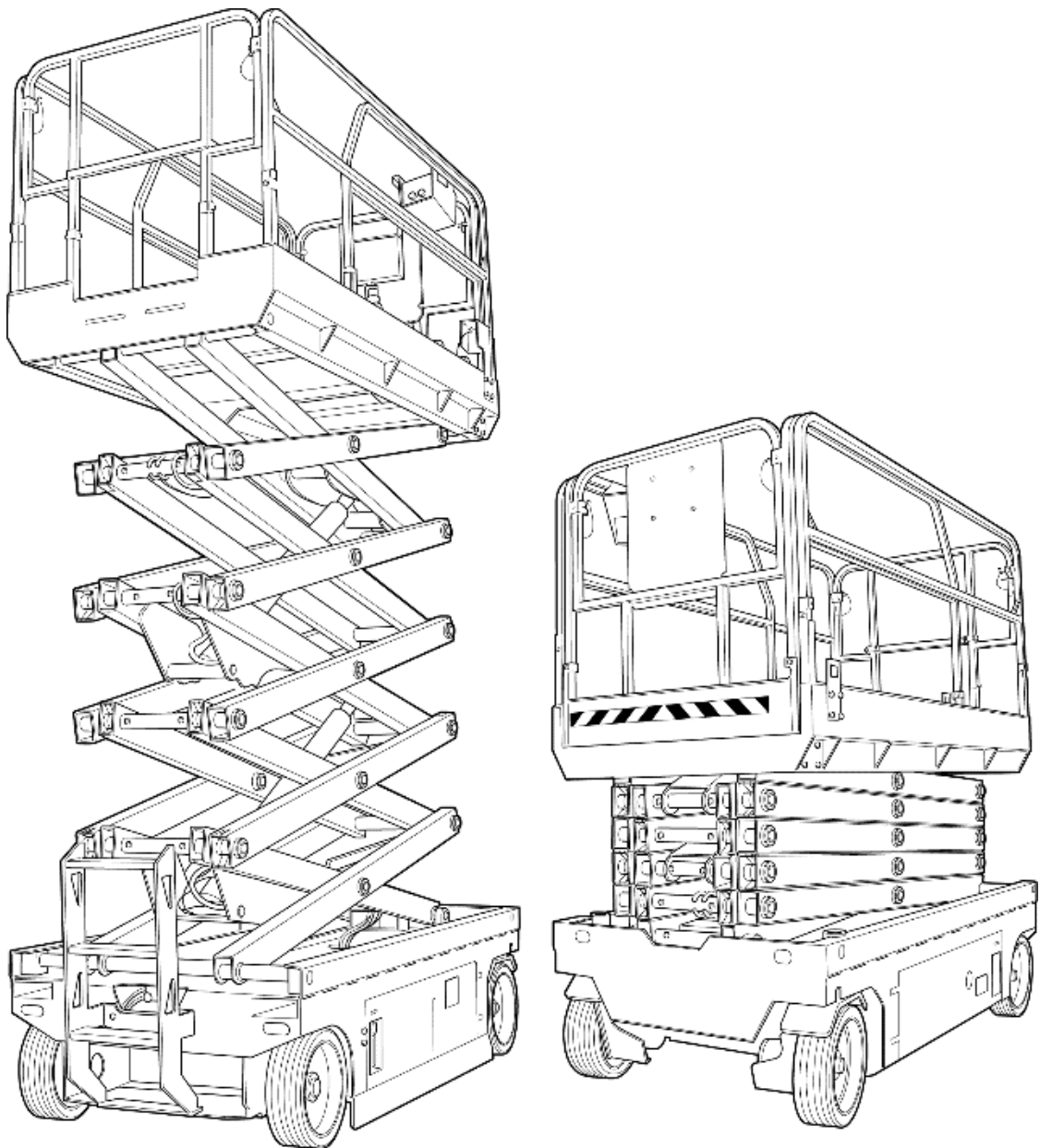

Self-Propelled Scissor Lift

XE65N / XE80N / XE80C / XE80W / XE100C / XE100W
XE120W / XE140W / XE160W



Original Instructions
Second Edition
Copyright © Mantall 2016

1 Contents

| | | |
|----------|---|-----------|
| 2 | Introduction | 4 |
| 2.1 | Hazard Classification | 4 |
| 2.2 | Intended Use | 4 |
| 2.3 | Declaration of Conformity | 5 |
| 2.4 | Safety Sign Maintenance | 6 |
| 3 | Safety | 6 |
| 3.1 | Personal Safety | 6 |
| 3.1.1 | Personal Fall Protection | 6 |
| 3.2 | Work Area Safety | 6 |
| 3.2.1 | Electrocution Hazards | 6 |
| 3.2.2 | Tip-Over Hazards | 7 |
| 3.2.3 | Operation on Slopes Hazards | 8 |
| 3.2.4 | Fall Hazards | 9 |
| 3.2.5 | Collision Hazards | 9 |
| 3.2.6 | Bodily Injury Hazards | 10 |
| 3.2.7 | Component Damage Hazards | 10 |
| 3.2.8 | Explosion and Fire Hazards | 10 |
| 3.2.9 | Damaged Machine Hazards | 11 |
| 3.2.10 | Crushing Hazards | 11 |
| 3.3 | Battery Safety | 11 |
| 3.3.1 | Burn Hazards | 11 |
| 3.3.2 | Explosion Hazards | 12 |
| 3.3.3 | Component Damage Hazards | 12 |
| 3.3.4 | Electrocution Hazards | 12 |
| 3.3.5 | Tip-Over Hazards | 12 |
| 3.3.6 | Lifting Hazards | 12 |
| 4 | Machine Identification | 13 |
| 5 | Controls | 14 |
| 5.1 | Ground Control Panel | 14 |
| 5.1.1 | Identification | 14 |
| 5.1.2 | Functionalities | 15 |
| 5.2 | Type A Platform Controller | 16 |
| 5.2.1 | Identification | 16 |
| 5.2.2 | Functionalities | 17 |
| 5.3 | Type B Platform Controller | 18 |
| 5.3.1 | Identification | 18 |
| 5.3.2 | Functionalities | 19 |
| 6 | Inspections | 20 |
| 6.1 | Pre-Operation Inspection | 20 |
| 6.1.1 | Fundamentals | 20 |
| 6.1.2 | Inspection | 20 |
| 6.2 | Function Tests | 22 |
| 6.2.1 | Fundamentals | 22 |
| 6.2.2 | Tests | 22 |
| 6.3 | Work Place Inspection | 28 |
| 6.3.1 | Fundamentals | 28 |

| | | |
|-----------|---|-----------|
| 6.3.2 | Inspection | 28 |
| 7 | Operating Instructions | 29 |
| 7.1 | Fundamentals | 29 |
| 7.2 | Emergency Stop | 29 |
| 7.3 | Emergency Lowering | 29 |
| 7.4 | Operation From the Ground | 30 |
| 7.5 | Operation From the Platform | 30 |
| 7.6 | Extend and Retract the Platform | 32 |
| 7.7 | Operation From Ground with Platform Controller | 33 |
| 7.8 | After Each Use | 33 |
| 7.9 | Fold Down of the Platform Guard Rails | 33 |
| 7.10 | Battery and Charger Instructions | 34 |
| 7.10.1 | To Charge Battery | 34 |
| 7.10.2 | Dry Battery Filling and Charging Instructions | 34 |
| 8 | Error Codes (Only for Type B Platform Controller) | 35 |
| 9 | Lifting Instructions | 36 |
| 9.1 | Lifting with Forklift | 36 |
| 9.2 | Lifting with Crane | 36 |
| 10 | Transport Instructions | 37 |
| 10.1 | Towing the Machine (Only for Hydraulically Driven Machines) | 37 |
| 10.2 | Securing the Machine to a Transport Vehicle | 38 |
| 11 | Maintenance | 38 |
| 11.1 | Check the Hydraulic Oil Level | 38 |
| 11.2 | Add Hydraulic Oil | 38 |
| 11.3 | Check the Batteries | 39 |
| 11.4 | Lubrication Locations | 39 |
| 12 | Specifications | 40 |
| 12.1 | Narrow / Compact Models | 40 |
| 12.2 | Wide Models | 41 |

Important

Read, understand and obey these safety rules and operating instructions before operating this machine. Only trained and authorized personnel shall be permitted to operate this machine. This Operator's Manual should be considered a permanent part of your machine and should remain with the machine at all times.

2 Introduction



DANGER

Failure to obey the instructions and safety rules in this Operator's Manual will result in serious injury or death.



Do Not Operate Unless:

- You learn and practice the principles of safe machine operation contained in this Operator's Manual.
 1. **Avoid hazardous situations.**
Know and understand the safety rules before going on to the next section.
 2. Always perform a pre-operation inspection.
 3. Always perform function tests prior to use.
 4. Inspect the workplace.
 5. Only use the machine as it was intended.
- You read, understand and obey the manufacturer's instructions and safety rules, Operator's Manual and machine decals.
- You read, understand and obey employer's safety rules and worksite regulations.
- You read, understand and obey all applicable governmental regulations.
- You are properly trained to safely operate the machine.

2.1 Hazard Classification



DANGER

Indicates a hazardous situation which, if not avoided, will result in serious injury or death.



WARNING

Indicates a hazardous situation which, if not avoided, could result in serious injury or death.



CAUTION

Indicates a hazardous situation which, if not avoided, could result in minor or moderate injury.

2.2 Intended Use

This machine is intended to be used only to lift personnel, along with their tools and materials to an aerial work site.

Operator's Manual

Self-Propelled Scissor Lift

2.3 Declaration of Conformity

EG Declaration of Conformity

According to the Machine Directive 2006/42/EG (annex II-1-A)

This declaration of Conformity is issued under the sole responsibility of the manufacturer:
Manufacturer : Mantall Heavy Industry Co.,LTD
Address : No 62, Binhai Avenue, Binhai Industrial Park, Qidong City, China
Telephone : +86 513 83896888
Website : <http://www.mantall.com>
E-mail : sales@mantall.com / service@mantall.com



Authorized EU representative to compile the technical file on behalf of the manufacturer:
Name :
Address :
Telephone :
Website :
E-mail :

Mantall declares that the machinery described below is complying with all essential requirements of the Machinery Directive 2006/42/EG. This declaration relates exclusively to the machinery in the state in which it was placed on the market, and excludes components which are added and/or operations carried out subsequently by the final user. The declaration is no more valid, if the machinery is modified without agreement of the manufacturer.

Object of Declaration:

Product Name : Self Propelled Scissor Lift
Models/Types : XE65N / XE80N / XE80C / XE80W / XE100C / XE100W / XE120W / XE140W / XE150W
Serial number :
Notified Body : SGS United Kingdom Limited, Unit 10,
Bowburn South Industrial Estate, Bowburn Durham DH6 5AD, England
No of Notified Body : 0800
No of EC type-examination certificate : MDC 1028

And are in conformity with the following harmonized standards:

- EN ISO 12100:2010 Safety of machinery – General principles for design – Risk assessment and risk reduction
- EN 280:2001 + A2:2009 Mobile Elevating Work Platforms – Design calculations – Stability criteria – Construction – Safety – Examinations and tests
- EN 60204-1:2006/AC:2010 Safety of machinery – Electrical equipment of machines – Part 1: General requirements
- EN ISO 13849-1:2006/AC:2009 Safety of machinery – Safety-related parts of control systems – Part 1: General principles for design

Signed for and on behalf of:

Company : Mantall Heavy Industry Co. LTD
Name : Zhiqin Yu
QC Director
Place & Date :
Address : Nantong, China
Date : 26th March , 2014



2.4 Safety Sign Maintenance

Replace any missing or damaged safety signs. Keep operator safety in mind at all times. Use mild soap and water to clean safety signs. Do not use solvent-based cleaners because they may damage the safety sign material.

3 Safety

3.1 Personal Safety

3.1.1 Personal Fall Protection

Personal fall protection equipment (PFPE) is required when operating this machine.

All PFPE must comply with applicable governmental regulations, and must be inspected and used in accordance with the manufacturer's Safety Instructions.

3.2 Work Area Safety

3.2.1 Electrocuting Hazards

This machine is not electrically insulated and will not provide protection from contact with or proximity to electrical current.

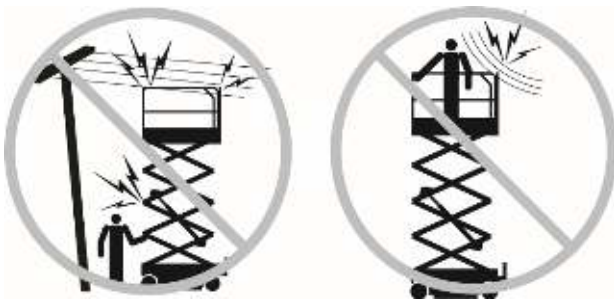

Maintain safe distances from electrical power lines and apparatus in accordance with applicable governmental regulations and the following chart.

| Line Voltage | Required Clearance | |
|----------------|--------------------|---------|
| 0 to 300V | Avoid Contact | |
| 300V to 50KV | 10 ft | 3.0 m |
| 50KVto 200KV | 15 ft | 4.60 m |
| 200KVto 350KV | 20 ft | 6.10 m |
| 350KVto 500KV | 25 ft | 7.62 m |
| 500KVto 750KV | 35 ft | 10.67 m |
| 750KVto 1000KV | 45 ft | 13.72 m |

Allow for platform movement, electrical line sway or sag and beware of strong or gusty winds.

Keep away from the machine if it contacts energized power lines. Personnel on the ground or in the platform must not touch or operate the machine until energized power lines are shut off.

Do not operate the machine during lightning or stormy weather.

Do not use the machine as a ground for welding.

3.2.2 Tip-Over Hazards

Occupants and equipment shall not exceed the maximum capacity of the platform or the platform extension.

Refer to the Specifications for maximum capacity of the platform and platform extension.

Do not raise the platform unless the machine is on a firm, level surface.

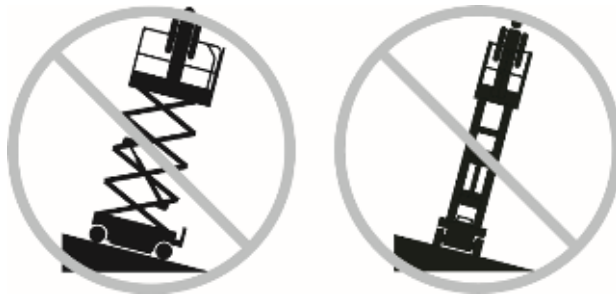

Do not depend on the tilt alarm as a level indicator. The tilt alarm sounds on the chassis only when the machine is on a slope.

If tilt alarm sounds:

Lower the platform. Move the machine to a firm, level surface. If the tilt alarm sounds when the platform is raised, use extreme caution to lower the platform.

Do not alter or disable limit switches.

Do not drive over 0.64 ft/s (0,7 km/h) with the platform raised.

Use extreme care and slow speeds while driving the machine in the stowed position across uneven terrain, debris, unstable or slippery surfaces and near holes and drop-offs.

Do not use the platform controller to free a platform that is caught, snagged or otherwise prevented from normal motion by an adjacent structure. All personnel must be removed from the platform before attempting to free the platform using the ground control panel.



Do not push off or pull toward any object outside of the platform.

Do not tie the platform to adjacent structures.

Do not place loads outside the platform perimeter.

Do not alter or disable machine components that in any way affect safety and stability.

Do not modify an aerial work platform.

Mounting attachments for holding tools or other materials onto the platform, floor plate or guard rail system can increase the weight in the platform and the surface area of the platform or the load.

Do not replace items critical to machine stability with items of different weight or specification.

Do not raise the platform when wind speeds may exceed 12,5 m/s. If wind speeds exceed 12,5 m/s when the platform is raised, lower the platform and stop operating the machine.

Do not operate the machine in strong or gusty winds. Do not increase the surface area of the platform or the load. Increasing the area exposed to the wind will decrease machine stability.

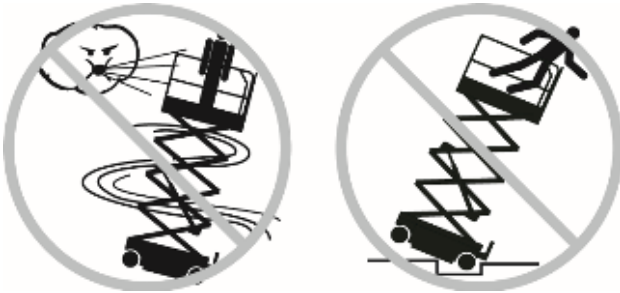

Do not drive the machine on or near uneven terrain, unstable surfaces or other hazardous conditions with the platform raised.

Do not place or attach fixed or overhanging loads to any part of this machine.



Do not place ladders or scaffolds in the platform or against any part of this machine.

Do not transport tools and materials unless they are evenly distributed and can be safely handled by person(s) in the platform.

Do not use machine on a moving or mobile surface or vehicle.

Be sure all tires are in good condition, castle nuts are properly tightened and cotter pins are properly installed.

Do not use batteries that weigh less than the original equipment. Batteries are used as counterweight and are critical to machine stability. Check the specifications of the batteries for their weight.

Do not use the machine as a crane.

Do not push the machine or other objects with the platform.

Do not contact adjacent structures with the platform.

3.2.3 Operation on Slopes Hazards

Do not drive the machine on a slope that exceeds the vertical or lateral slope rating of the machine.

Slope ratings apply to the machine in the stowed position.

Note: Slope ratings are subject to ground conditions and adequate traction.

Refer to the Specifications for vertical and lateral slope ratings of the machine.

3.2.4 Fall Hazards

Personnel in the platform should wear a Personal Fall Protection Equipment (PFPE) and comply with applicable governmental regulations. Attach the PFPE to one of the anchor points of the platform.

Do not sit, stand or climb on the platform guard rails. Maintain a firm footing on the platform floor at all times.

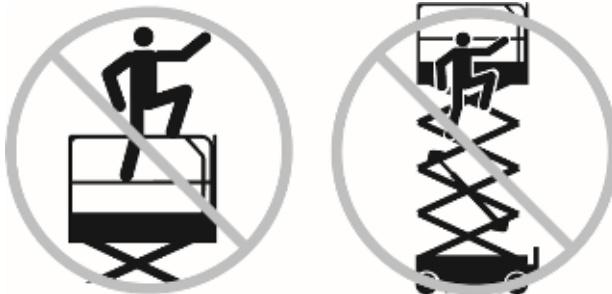

Do not climb down from the platform when raised.

Keep the platform floor clear of debris.

Lower the entry bar or close the entry gate before operating.

Do not operate the machine unless the guard rails are properly installed and the entry is secured for operation.

3.2.5 Collision Hazards

Do not operate the machine with the chassis trays open.

Be aware of limited sight distance and blind spots when driving or operating.



Be aware of extended platform position when moving the machine.

Machine must be on level surface or secured before releasing brakes.

Operators must comply with employer, job site and governmental rules regarding use of personal protective equipment.

It is recommended that operators wear an approved helmet when operating the machine.

Check work area for overhead obstructions or other possible hazards.



Be aware of crushing hazard when grasping the platform guard rail.

Do not operate the machine in the path of any crane or moving overhead machinery unless the controls of the crane have been locked out and / or precautions have been taken to prevent any potential collision.

No stunt driving or horseplay while operating the machine.

Do not lower the platform unless the area below is clear of personnel and obstructions.



Limit travel speed according to condition of ground surface, congestion, slope, location of personnel and any other factors which may cause collision.

3.2.6 Bodily Injury Hazards

Do not operate the machine with a hydraulic oil or air leak. An air leak or hydraulic leak can penetrate and/or burn skin.

Improper contact with components under any cover will cause serious injury. Only trained maintenance personnel should access compartments. Access by the operator is only advised when performing a pre-operation inspection. All compartments must remain closed and secured during operation.

3.2.7 Component Damage Hazards

Do not use machine as a ground for welding.

3.2.8 Explosion and Fire Hazards

Do not operate the machine or charge the battery in hazardous locations or locations where potentially flammable or explosive gases or particles may be present.

3.2.9 Damaged Machine Hazards

Do not use a damaged or malfunctioning machine.

Conduct a thorough pre-operation inspection of the machine and test all functions before each work shift. Immediately tag and remove a damaged or malfunctioning machine from service.

Be sure all maintenance has been performed as specified in this Operator's Manual.

Be sure all decals are in place and legible.

Be sure the Operator's Manual is complete, legible and in the storage container located on the platform.

3.2.10 Crushing Hazards

Keep hands and limbs out of scissors.

Use common sense and planning when operating the machine with the platform controller from the ground. Maintain safe distances between the operator, the machine and fixed objects.

Make sure to support the platform guard rails when removing the fixing pins. Do not allow the platform guard rails to fall.

3.3 Battery Safety

3.3.1 Burn Hazards

Batteries contain acid. Always wear protective clothing and eyewear when working with batteries.

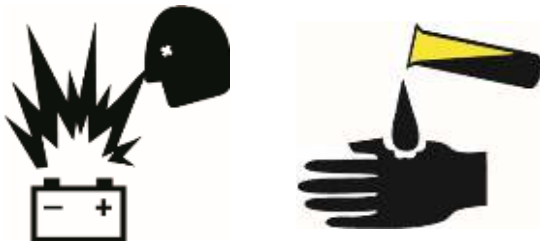

Avoid spilling or contacting battery acid. Battery acid spills can be neutralized with a mixture of baking soda and water.

Do not expose the batteries or the charger to water and/or rain during charging.

3.3.2 Explosion Hazards



Keep sparks, flames and lighted tobacco away from batteries. Batteries emit an explosive gas. The battery tray should remain open during the entire charging cycle. Do not contact the battery terminals or the cable clamps with tools that may cause sparks.

3.3.3 Component Damage Hazards

Do not use any battery charger greater than 24V to charge the batteries.

3.3.4 Electrocutation Hazards



Connect the battery charger to a grounded, AC, 3-wire electrical outlet only. Inspect daily for damaged cord, cables and wires. Replace damaged items before operating. Avoid electrical shock from contact with battery terminals. Remove all rings, watches and other jewelry.

3.3.5 Tip-Over Hazards

Do not use batteries that weigh less than the original equipment. Batteries are used as counterweight and are critical to machine stability. Check the specifications of the batteries for their weight.

3.3.6 Lifting Hazards

Use the appropriate number of people and proper lifting techniques when lifting batteries.

4 Machine Identification

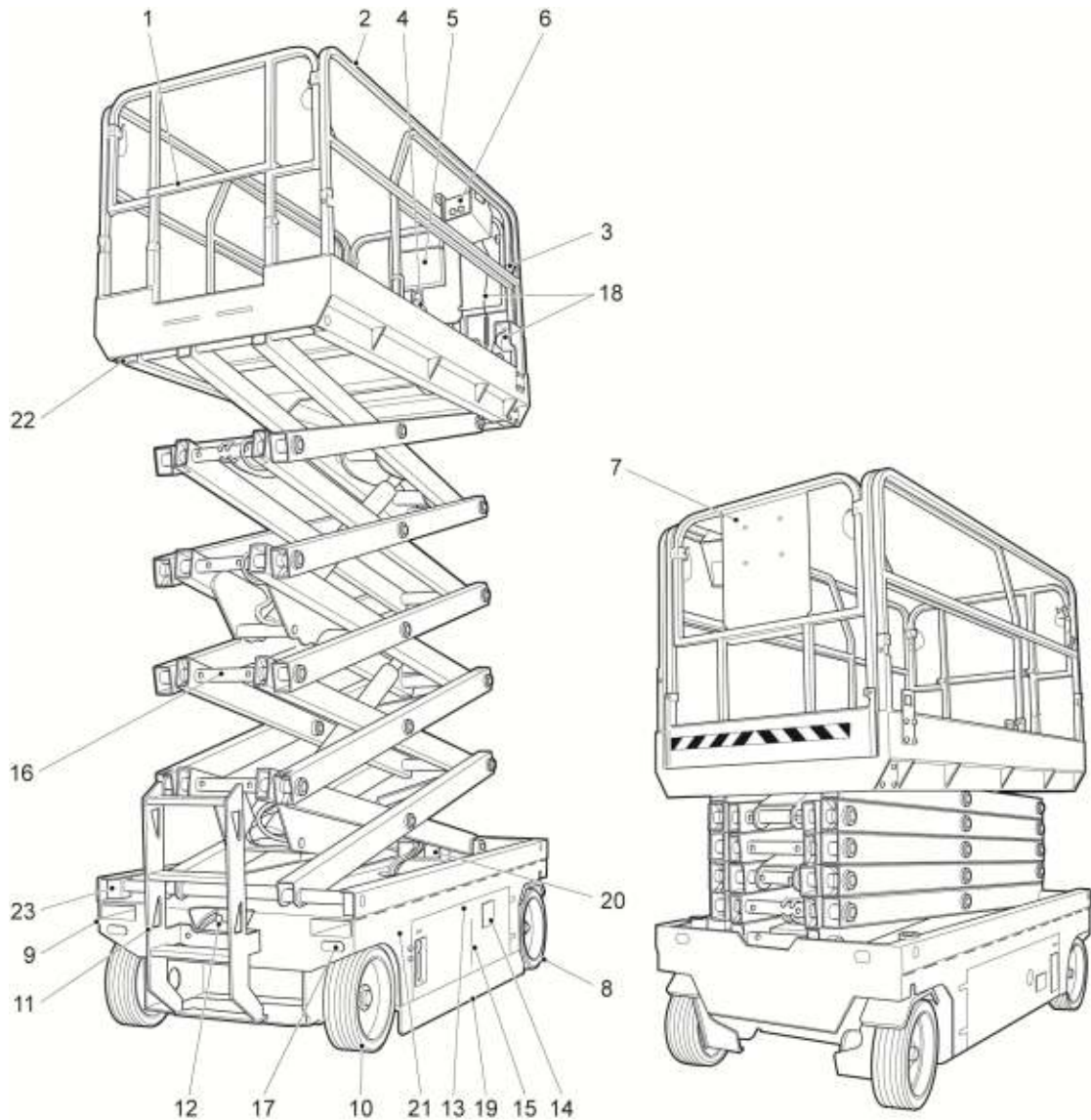

- | | | |
|--|--|---|
| 1 Platform entry gate or bar | 9 Battery side cover | 16 Safety arm |
| 2 Platform guard rails | 10 Non-steer tire | 17 Tie down / lift points |
| 3 Personal Fall Protection Equipment (PFPE) anchor point | 11 Entry ladder | 18 AC wiring to platform |
| 4 Platform extension lock pedal | 12 Brake release pump knob, brake release knob and manual lowering knob (only for hydraulically driven machines) | 19 Pothole guards |
| 5 Manual storage container | 13 Ground control side cover | 20 Limit switch for platform in stowed position |
| 6 Platform controller | 14 Ground control panel | 21 Limit switch for pothole guards (behind ground control side cover) |
| 7 Platform extension | 15 Hydraulic oil level indicator | 22 Wear pads |
| 8 Steer tire | | |

5 Controls

5.1 Ground Control Panel

**CAUTION**

Only use the ground control panel as an emergency control. Always use the platform controller as standard operation control.

5.1.1 Identification

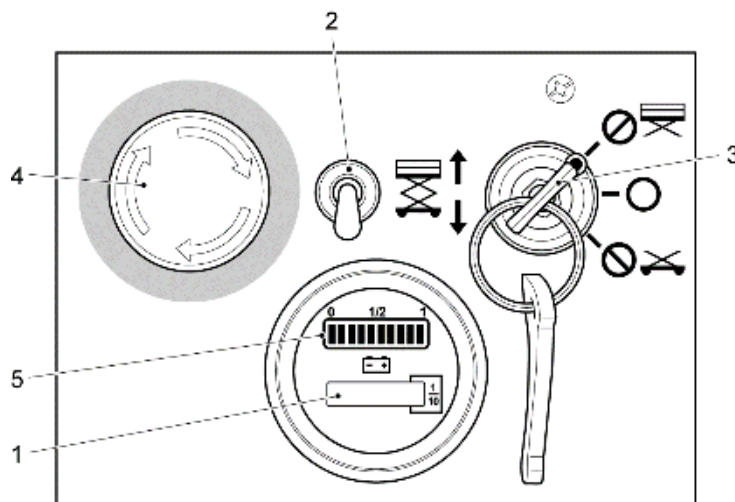

- 1 Hour meter
- 2 Platform up/down switch
- 3 Key switch for platform/off/ground control selection
- 4 Emergency Stop button
- 5 Battery indicator

5.1.2 Functionalities

1. Hour meter

Indicates the number of hours the machine has been used.

2. Platform up/down switch

Move and hold the platform up/down switch to the upper position to raise the platform.

Move and hold the platform up/down switch to the lower position to lower the platform.

3. Key switch for platform/off/ground selection

Turn the key switch to the platform position and the platform controller will operate.

Turn the key switch to the off position and the machine will be off.

Turn the key switch to the ground position and the ground control panel will operate.

4. Emergency Stop button

Push in the Emergency Stop button to the off position to stop all functions.

Turn out the Emergency Stop button to the on position to operate the machine.

5. Battery indicator

Indicates how much the battery is charged.

5.2 Type A Platform Controller

5.2.1 Identification

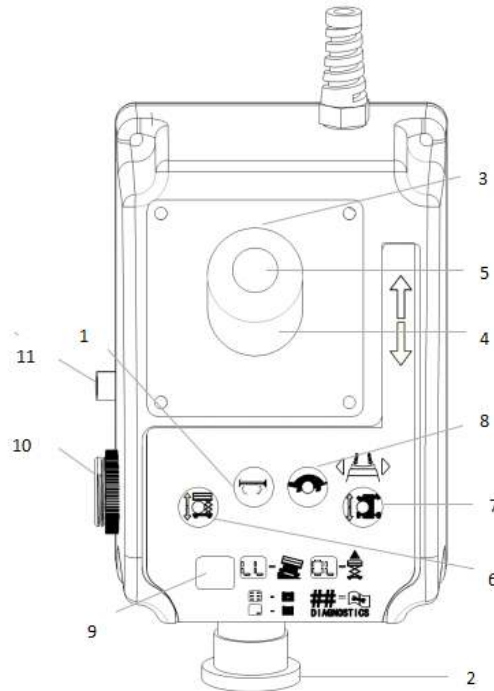

- | | | | |
|---|---|----|---|
| 1 | Horn button | 7 | Drive function enable button with indicator light |
| 2 | Emergency Stop button | 8 | Drive speed selector button with indicator light |
| 3 | Function enable switch | 9 | LCD readout screen |
| 4 | Proportional control handle for lift/drive function | 10 | Tilt Buzzer |
| 5 | Thumb rocker switch for steering function | 11 | Overload indicator light |
| 6 | Lift function enable button with indicator light | | |

5.2.2 Functionalities

1. Horn button

Press this button and the horn will sound.

Release the button and the horn will stop.

2. Emergency Stop button

Push in the Emergency Stop button to the off position to stop all functions.

Turn out the Emergency Stop button to the on position to operate the machine.

3. Function enable switch

Press and hold the function enable switch to enable the lift/drive function.

4. Proportional control handle for lift/drive function

This control handle works in combination with the lift or drive function enable button.

With the lift function enabled, move the control handle forward/backward and the platform will raise/lower.

With the drive function enabled, move the control handle forward/backward and the machine will move forward/backward.

5. Thumb rocker switch for steering function

Press the left side of the thumb rocker switch and the machine will steer to the left.

Press the right side of the thumb rocker switch and the machine will steer to the right.

6. Lift function enable button with indicator light

Press this button to enable the lift function.

Indicator light will be on when lift function is enabled.

7. Drive function enable button with indicator light

Press this button to enable the drive function.

Indicator light will be on when drive function is enabled.

8. Drive speed selector button with indicator light

Press this button to select the fast/slow drive speed.

Indicator light off: slow drive speed.

Indicator light on: fast drive speed.

9. LCD readout screen

Displays the battery status.

10. Tilt Buzzer

When the machine is tilt, the buzzer will alarm

11. Overload indicator light

When the machine is overload, the light will turn on.

5.3 Type B Platform Controller

5.3.1 Identification

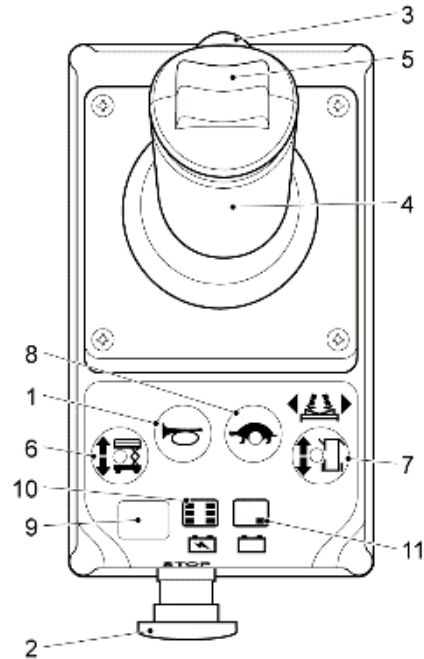

- | | | | |
|---|---|----|---|
| 1 | Horn button | 7 | Drive function enable button with indicator light |
| 2 | Emergency Stop button | 8 | Drive speed selector button with indicator light |
| 3 | Function enable switch | 9 | LCD readout screen |
| 4 | Proportional control handle for lift/drive function | 10 | Battery status decal—battery full |
| 5 | Thumb rocker switch for steering function | 11 | Battery status indicator |
| 6 | Lift function enable button with indicator light | | |

5.3.2 Functionalities

1. Horn button

Press this button and the horn will sound.

Release the button and the horn will stop.

2. Emergency Stop button

Push in the Emergency Stop button to the off position to stop all functions.

Turn out the Emergency Stop button to the on position to operate the machine.

3. Function enable switch

Press and hold the function enable switch to enable the lift/drive function.

4. Proportional control handle for lift/drive function

This control handle works in combination with the lift or drive function enable button.

With the lift function enabled, move the control handle forward/backward and the platform will raise/lower.

With the drive function enabled, move the control handle forward/backward and the machine will move forward/backward.

5. Thumb rocker switch for steering function

Press the left side of the thumb rocker switch and the machine will steer to the left.

Press the right side of the thumb rocker switch and the machine will steer to the right.

6. Lift function enable button with indicator light

Press this button to enable the lift function.

Indicator light will be on when lift function is enabled.

7. Drive function enable button with indicator light

Press this button to enable the drive function.

Indicator light will be on when drive function is enabled.

8. Drive speed selector button with indicator light

Press this button to select the fast/slow drive speed.

Indicator light off: slow drive speed.

Indicator light on: fast drive speed.

9. LCD readout screen

Displays the error codes.

10. Battery status decal – battery full

If this view is displayed in the battery status indicator, battery is full.

11. Battery status indicator

Indicates the status of the battery.

6 Inspections

6.1 Pre-Operation Inspection



Do Not Operate Unless:

- You learn and practice the principles of safe machine operation contained in this Operator's Manual.
 1. Avoid hazardous situations.
 2. **Always perform a pre-operation inspection.**

Know and understand the pre-operation inspection before going on to the next section.

3. Always perform function tests prior to use.
4. Inspect the workplace.
5. Only use the machine as it was intended.

6.1.1 Fundamentals

- It is the responsibility of the operator to perform a pre-operation inspection and routine maintenance.
- The pre-operation inspection is a visual inspection performed by the operator prior to each work shift. The inspection is designed to discover if anything is apparently wrong with a machine before the operator performs the function tests.
- The pre-operation inspection is also used to determine if routine maintenance procedures are required. Only routine maintenance items specified in this Operator's Manual may be performed by the operator.
- Refer to the list in Inspection on page 20-21 and check each of the items and locations for modifications, damage or loose or missing parts.
- A damaged or modified machine must never be used. If damage or any variation from factory delivered condition is discovered, the machine must be tagged and removed from service.
- Repairs to the machine may only be made by a qualified service technician, according to the manufacturer's specifications. After repairs are completed, the operator must perform a pre-operation inspection again before performing the function tests.

6.1.2 Inspection

- Be sure that the Operator's Manual is complete, legible and in the storage container located on the platform.
- Check for hydraulic oil leaks and proper oil level. Add oil if needed. See Maintenance section.
- Check for battery fluid leaks and proper fluid level. Add distilled water if needed. See Maintenance section.

- Check the following components or areas for damage, modifications and improperly installed or missing parts:
 - Electrical components, wiring and electrical cables
 - Hydraulic power unit, tank, hoses, fittings, cylinders and manifolds
 - Battery pack and connections
 - Drive motors
 - Wear pads
 - Tires and wheels
 - Limit switches, alarms and horn
 - Nuts, bolts and other fasteners
 - Platform entry bar or gate
 - Brake release components
 - Safety arm
 - Pothole guards
 - Platform extension
 - Scissor pins and retaining fasteners
 - Platform control joystick

- Check entire machine for:
 - Cracks in welds or structural components.
 - Cracks in anchor points for Personal Fall Protection Equipment (PFPE).
 - Damage to machine.
 - Excessive rust, corrosion or oxidation.
 - Be sure that all structural and other critical components are present and all associated fasteners and pins are in place and properly tightened.
 - Platform guard rails are installed and bolts are fastened.
 - Be sure that the chassis trays are in place, latched and properly connected.

6.2 Function Tests

Do Not Operate Unless:



- You learn and practice the principles of safe machine operation contained in this Operator's Manual.
 1. Avoid hazardous situations.
 2. Always perform a pre-operation inspection.
 3. **Always perform function tests prior to use.**

Know and understand the function tests before going on to the next section.

4. Inspect the workplace.
5. Only use the machine as it was intended.

6.2.1 Fundamentals

- The Function Tests are designed to discover any malfunctions before the machine is put into service. The operator must follow the step-by-step Instructions to test all machine functions.
- A malfunctioning machine must never be used. If malfunctions are discovered, the machine must be tagged and removed from service. Repairs to the machine may only be made by a qualified service technician, according to the manufacturer's specifications.
- After repairs are completed, the operator must perform a pre-operation inspection and function tests again before putting the machine into service.

6.2.2 Tests

1. Select a test area that is firm, level and free of obstruction.
2. Make sure the battery pack is connected.

At the Ground Control Panel



CAUTION

Only use the ground control panel as an emergency control. Always use the platform controller as standard operation control.

3. Turn out the Emergency Stop buttons of the platform controller and ground control panel to the ON position.
4. Turn the key switch of the ground control panel to ground position.

Test Emergency Stop

5. Push in the Emergency Stop button of the ground control panel to the OFF position.
 - **Result:** No functions should operate.
6. Turn out the Emergency Stop button of the ground control panel to the ON position.

Test the Up/Down Functions

The audible warnings on this machine and the standard horn all come from the same central alarm. The horn is a continuous tone. The descent alarm is an intermittent tone and becomes continuous when the platform reaches a height of 5 ft (1,5 m) above its stowed position. The tilt alarm and the overload alarm are all continuous tones. An optional automotive-style horn is also available.

7. Move and hold the platform up/down switch to the upper position to activate the up function.

Result: The platform should raise. The pothole guards should deploy.

Note: Do not raise the platform more than 5ft (1,5 m).

8. Move and hold the platform up/down switch to the lower position to activate the down function.

- **Result:** The platform should lower. The descent alarm should sound while the platform is lowering.

Note: When releasing the platform up/down switch, the platform should stop raising/lowering.

Test the Manual Lowering (Only For Hydraulically Driven Machines)

9. Push and hold the platform up/down switch to the upper position to activate the up function and raise the platform approximately 2 ft (0,6 m).

10. Pull the manual lowering knob located at the back of the chassis.

- **Result:** The platform should lower. The descent alarm will not sound.

At the Platform Controller

11. Turn the key switch of the ground control panel to platform position.

Test Emergency Stop

12. Push in the Emergency Stop button of the platform controller to the OFF position.

- **Result:** No functions should operate.

13. Turn out the Emergency Stop button of the platform controller to the ON position.

Test the Horn

14. Push the horn button.

- **Result:** The horn should sound.

Test the Function Enable Switch

15. Do not press the function enable switch on the control handle.

16. Slowly push the control handle forward, then pull the control handle backward.

- **Result:** No functions should operate.

Test the Up/Down Functions

17. **Type A/B controller:** press the lift function enable button. Indicator light must be on..
18. Slowly push the control handle forward.
 - **Result:** The platform should raise. The pothole guards should deploy.
19. Release the control handle.
 - **Result:** The platform should stop raising.
20. Press and hold the function enable switch on the control handle.
21. Slowly pull the control handle backward.
 - **Result:** The platform should lower. The descent alarm should sound while the platform is lowering.
22. Release the control handle.
 - **Result:** The platform should stop lowering.

Test the Lowering Safety stop

23. Press and hold the function enable switch on the control handle.
24. Slowly push the control handle forward and raise the platform more than 6.56 ft (2m) from its stowed position.
 - **Result:** The pothole guards should deploy.
25. Press and hold the function enable switch on the control handle.
26. Slowly pull the control handle backward and lower the platform.
 - **Result:** The platform lowering should stop automatically when the platform is at a height of 5 ft (1,5 m) above its stowed position. An alarm should sound.
27. Release the control handle and wait for 3 seconds.
28. Press and hold the function enable switch on the control handle.
29. Slowly pull the control handle backward and completely lower the platform.

Test the Steering

Note: When performing the steering and drive function tests, stand in the platform facing the steer end of the machine.

30. **Type A /B controller:** press the drive function enable button. Indicator light must be on.
31. Press and hold the function enable switch on the control handle.
32. Press the thumb rocker switch on top of the control handle to the left.
 - **Result:** The steering wheels should turn to the left.
33. Press and hold the function enable switch on the control handle.
34. Press the thumb rocker switch on top of the control handle to the right.
 - **Result:** The steering wheels should turn to the right.

Test Drive and Braking

35. Press and hold the function enable switch on the control handle.
36. Slowly push the control handle forward until the machine begins to move, then return the control handle to the center position.
 - **Result:** The machine should move forward, then stop abruptly.
37. Press and hold the function enable switch on the control handle.
38. Slowly pull the control handle backward until the machine begins to move, then return the control handle to the center position.
 - **Result:** The machine should move backward, then stop abruptly.



CAUTION

The drive brakes must be able to hold the machine on any slope within its slope ratings.

Test Drive Speed

39. **Type A/B controller:** press the drive speed selector button. Indicator light must be on.
40. Press and hold the function enable switch on the control handle.
41. Slowly push the control handle to the full drive (forward or backward) position.
 - **Result:** The machine should move with fast speed.
42. **Type A/B controller:** press the drive speed selector button. Indicator light must be off.
43. Press and hold the function enable switch on the control handle.
44. Slowly push the control handle to the full drive (forward or backward) position.
 - **Result:** The machine should move with slow speed.

Test Limited Drive Speed

45. **Type A/B controller:** press the lift function enable button. Indicator light must be on.
46. Press and hold the function enable switch on the control handle.
47. Slowly push the control handle forward and raise the platform more than 5 ft (1,5 m) from its stowed position.
 - **Result:** The pothole guards should deploy.
48. **Type A/B controller:** press the drive function enable button. Indicator light must be on.
49. Press and hold the function enable switch on the control handle.
50. Slowly push the control handle to the full drive (forward or backward) position.
 - **Result:** The maximum achievable drive speed with the platform raised should not exceed 0.64 ft/s (0,7 km/h).

**WARNING**

If the drive speed with the platform raised exceeds 0.64 ft/s (0,7 km/h), immediately tag and remove the machine from service.

Test the Tilt Sensor Operation

Note: Perform this test from the ground using the platform controller. Do not stand in the platform.

51. **Type A/B controller:** press the lift function enable button. Indicator light must be on.
52. Press and hold the function enable switch on the control handle.
53. Slowly pull the control handle backward and completely lower the platform.
54. Place a 2x4 or similar piece of wood in front of the both wheels on one side.
55. **Type A/B controller:** press the drive function enable button. Indicator light must be on.
56. Press and hold the function enable switch on the control handle.
57. Slowly push the control handle forward and drive the machine onto the pieces of wood.
58. **Type A/B controller:** press the lift function enable button. Indicator light must be on.
59. Press and hold the function enable switch on the control handle.
60. Slowly push the control handle forward and raise the platform.
 - **Result:** When the platform is raised 5 ft (1,5 m) from its stowed position, an alarm should sound and platform raise is stopped. Drive function should not operate. Tilt indicator light on the platform controller should flash.
61. Pull the control handle backward and completely lower the platform.
62. Drive the machine off the pieces of wood and remove them.

Test the Overload Sensor Operation

63. Load the platform with a weight which is between 95% and 100% of the maximum allowed load.
64. Raise the platform.
 - **Result:** When the platform is raised 5 ft (1,5 m) from its stowed position, an alarm should sound and platform raise is stopped. Drive function should not operate. Overload indicator light on the platform controller should flash.

65. Completely lower the platform.
66. Remove the load from the platform.

Note: If the weight on the platform is 100% of the maximum allowed load or more, lowering the platform should not operate and the overload indicator light should light continuously. First remove the weight from the platform and then lower the platform.

Test the Pothole Guards

Note: The pothole guards should automatically deploy when the platform is raised. The pothole guards activate another limit switch which allows the machine to continue to function. If the pothole guards do not deploy, the machine will not drive.

67. Place a piece of wood between the wheels on one side of the machine (under the pothole guard).
68. Raise the platform.
 - **Result:** The pothole guards cannot deploy completely. When the platform is raised 5 ft (1,5 m) from its stowed position, the drive function should become inactive.
If the drive function operates, immediately tag and remove the machine from service.
69. Completely lower the platform and remove the piece of wood.
70. Raise the platform again.
 - **Result:** When the platform is raised 5 ft (1,5 m) from its stowed position, the pothole guards should deploy.
71. Press on the pothole guards on one side, and then the other.
 - **Result:** The pothole guards should not move
72. Lower the platform.
 - **Result:** The pothole guards should return to the stowed position.

6.3 Work Place Inspection



Do Not Operate Unless:

- You learn and practice the principles of safe machine operation contained in this Operator's Manual.
 1. Avoid hazardous situations.
 2. Always perform a pre-operation inspection.
 3. Always perform function tests prior to use.
 4. **Inspect the workplace.**

Know and understand the work place inspection before going on to the next section.

5. Only use the machine as it was intended.

6.3.1 Fundamentals

- The Work Place Inspection helps the operator determine if the work place is suitable for safe machine operation. It should be performed by the operator prior to moving the machine to the work place.
- It is the operator's responsibility to read and remember the work place hazards. These work place hazards should be watched for and avoided while moving, setting up and operating the machine.

6.3.2 Inspection

Be aware of and avoid the following hazardous situations:

- drop-offs or holes
- bumps, floor obstructions or debris
- unstable or slippery surfaces
- overhead obstructions and high voltage conductors
- hazardous locations
- inadequate surface support to withstand all load forces imposed by the machine
- wind and weather conditions
- the presence of unauthorized personnel
- other possible unsafe conditions

7 Operating Instructions



Do Not Operate Unless:

- You learn and practice the principles of safe machine operation contained in this Operator's Manual.
 1. Avoid hazardous situations.
 2. Always perform a pre-operation inspection.
 3. Always perform function tests prior to use.
 4. Inspect the workplace.
 5. **Only use the machine as it was intended.**

7.1 Fundamentals

- The Operating Instructions section provides instructions for each aspect of machine operation. It is the operator's responsibility to follow all the safety rules and instructions in the Operator's Manual.
- Using the machine for anything other than lifting personnel and tools to an aerial work site is unsafe and dangerous.
- Only trained and authorized personnel should be permitted to operate a machine. If more than one operator is expected to use a machine at different times in the same work shift, they must all be qualified operators and are all expected to follow all safety rules and instructions in the Operator's Manual. This means that every new operator should perform a pre-operation inspection, function tests, and a work place inspection before using the machine.

7.2 Emergency Stop

Push in the Emergency Stop button of the ground control panel or platform controller to the OFF position to stop all functions.

Repair any function that operates when either Emergency Stop button is pushed in.

Push in and pull out the Emergency Stop button of the ground control panel or the platform controller to reset the system.

7.3 Emergency Lowering

In the event of a power failure, pull the manual lowering knob located at the back of the chassis to manually lower the platform.

7.4 Operation From the Ground



CAUTION

Only use the ground control panel as an emergency control. Always use the platform controller as standard operation control.

1. Turn the key switch of the ground control panel to ground position.
2. Turn out the Emergency Stop buttons of the ground control panel and platform controller to the ON position.

To Position Platform

Move and hold the platform up/down switch according to the markings on the control panel.

Drive and steering functions are not available from the ground control panel.

7.5 Operation From the Platform



WARNING

Personnel in the platform must wear a Personal Fall Protection Equipment (PFPE). Attach the PFPE to one of the anchor points of the platform before operating.

1. Install the platform controller in its storage position (front right) on the platform guard rails.
Note: A protection case was built around the platform controller to protect the platform controller from possible damage and is also used to easily install the platform controller in its storage position.
2. Connect the AC wiring connector of the platform controller to the electrical connector on the platform.
3. Turn the key switch of the ground control panel to platform position.
4. Turn out the Emergency Stop buttons of the ground control panel and platform controller to the ON position.

To Enter The Platform

For machines equipped with entry gate

1. Push the lever and open the platform entry gate.
2. Use the entry ladder to enter the platform.
3. Close the platform entry gate and use the lever to lock it.

For machines equipped with entry bar

1. Push the platform entry bar completely up.
2. Use the entry ladder to enter the platform.
3. Completely lower the platform entry bar.

To Position Platform

1. **Type A/B controller:** press the lift function enable button. The indicator light must be on.
2. press the lift function enable button. The indicator light must be on.
3. Press and hold the function enable switch on the control handle.
4. Move the control handle forward/backward to raise/lower the man platform.

To Steer

1. **Type A /B controller:** press the drive function enable button. The indicator light must be on.
2. Press and hold the function enable switch on the control handle.
3. Turn the steering wheels to the left/right by pressing the thumb rocker switch located on the top of the control handle to the left/right.

To Drive

1. **Type A /B controller:** press the drive function enable button. The indicator light must be on.
2. Use the drive speed selector button to select slow or fast speed.
3. Press and hold the function enable switch on the control handle.
4. Slowly push the control handle forward/backward to drive the machine forward/backward.
5. Increase speed: Slowly move the control handle off center.

Decrease speed: Slowly move the control handle towards center.

Stop: Return the control handle to center or release the function enable switch.

Note: Machine travel speed is restricted when the platform is raised more than 5 ft (1,5 m) from its stowed position.

Driving On a Slope

Determine the vertical and lateral slope ratings for the machine and determine the slope grade. Refer to the Specifications for vertical and lateral slope ratings of the machine.

Note: Slope ratings are subject to ground conditions and adequate traction.

1. If the slope exceeds the maximum vertical or lateral slope rating, the machine must be winched or transported up or down the slope. See Lifting Instructions and Transport Instructions.

Tilt Indicator Light On (Type A Controller) / Tilt Error Code Shown (Type B Controller)

If the buzzer alarm and LCD readout screen shows "LL" on the **Type A** platform controller / the tilt error code on the type B platform controller is shown "LL" and the buzzer alarm, there is a risk for tipping over and no functions (except lowering of the platform) will operate.

1. Completely lower the platform.
2. Drive the machine to a level surface before continuing operation.

Overload Indicator Light On (Type A Controller) / Overload Error Code Shown (Type B Controller)

If the overload indicator light on the **Type A** platform controller is on, the load on the platform is between 95% and 100% of the maximum allowed load. No functions (except lowering of the platform) will operate. An alarm will sound.

1. Completely lower the platform.

2. Remove weight from the platform.

If the the overload indicator light is still on, LCD readout screen shows "OL" and buzzer alarm on the **Type A** platform controller / OL is shown on the display of the type B platform controller and the buzzer alarm. the load on the platform is more than the maximum allowed load. No functions will operate. An alarm will sound.

If the platform is still overloaded, the overload indicator light will still on.

7.6 Extend and Retract the Platform

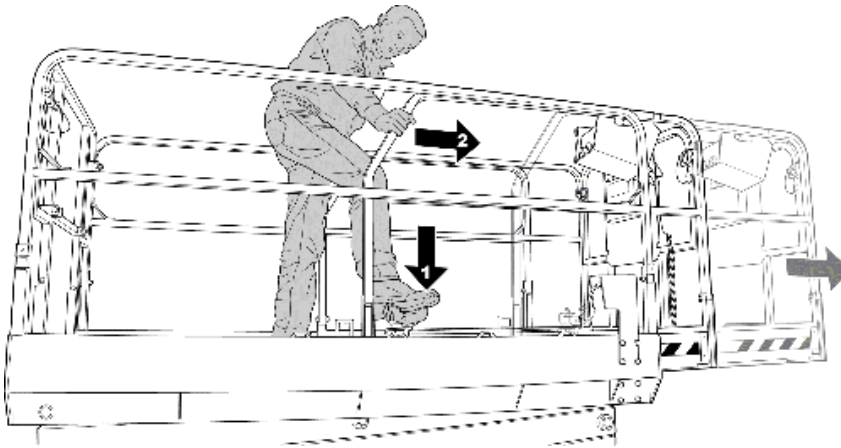

1. Step on the platform extension lock pedal to unlock the platform extension.
2. Grasp the guard rails of the platform extension and push to extend platform to the next position stop.
3. Repeat the previous steps to further extend the platform.

Note: Do not stand on the platform extension while trying to extend it.



CAUTION

Make sure there is enough space to extend the platform or raise the extended platform without risk of collision.



WARNING

The load on the platform extension must not exceed the maximum allowed load.

1. Step on the platform extension lock pedal to unlock the platform extension and pull the platform extension to retract it to the next position stop.



CAUTION

When retracting the platform extension from its most extended position, take care not to damage the wiring connector when stepping on the platform extension lock pedal.

2. Repeat the previous step to further retract the platform extension until completely retracted.

Note: Completely retract the platform extension before lowering the platform.



WARNING

Do not lower the platform when extended.

7.7 Operation From Ground with Platform Controller



WARNING

Maintain safe distances between operator, machine and fixed objects.

Be aware of the direction the machine will travel when using the platform controller.

7.8 After Each Use

1. Select a safe parking location with a firm and level surface, clear of obstruction and traffic.
2. Completely lower the platform to the stowed position.
3. Turn the key switch of the ground control panel to the off position and remove the key to secure the machine from unauthorized use.
4. Chock the wheels.
5. Charge the batteries.

7.9 Fold Down of the Platform Guard Rails

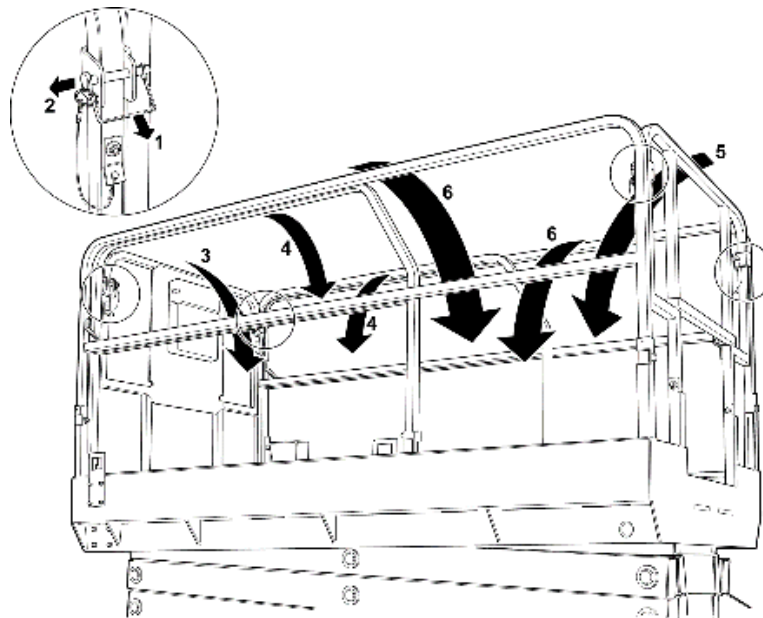

1. While supporting the front platform guard rail (equipped with the storage container), remove the retainer and pin from both sides of the front platform guard rail or loosen the fasteners and pivot the retainer brackets to the outside of the platform.
2. Have a second person supporting the two inner side platform guard rails which were secured to the front platform guard rail.

3. Gently lower the front platform guard rail on the platform floor while the second person holds the inner side guard rails to prevent them from falling down.
4. Gently lower the inner side guard rails.
5. While supporting the rear platform guard rail (equipped with entry gate or bar), remove the retainer and pin from both sides of the rear platform guard rail.
6. Have a second person supporting the two outer side platform guard rails which were secured to the rear platform guard rail.
7. Gently lower the rear platform guard rail on the platform floor while the second person holds the outer side guard rails to prevent them from falling down.
8. Gently lower the outer side guard rails.

7.10 Battery and Charger Instructions



Observe and Obey:

- Do not use external charger or booster battery.
- Charge battery in a well-ventilated area.
- Use proper AC input voltage for charging as indicated on the charger.
- Use only authorized battery and charger.

7.10.1 To Charge Battery

1. Make sure the batteries are connected before charging the batteries.
2. Remove the battery vent caps and check the battery acid level. If necessary, add only enough distilled water to cover the plates. Do not overfill prior to the charge cycle.
3. Install the battery vent caps.
4. Connect the battery charger to a grounded AC circuit by means of the electric plug at the back of the chassis.
5. The charger will indicate when the battery is fully charged.
6. Check the battery acid level when the charging cycle is complete. Replenish with distilled water to the bottom of the fill tube. Do not overfill.

7.10.2 Dry Battery Filling and Charging Instructions

1. Remove the battery vent caps and permanently remove the plastic seal from the battery vent openings.
2. Fill each cell with battery acid (electrolyte) until the level is sufficient to cover the plates.
Note: Do not fill to maximum level until the battery charge cycle is complete. Overfilling can cause the battery acid to overflow during charging. Battery acid spills can be neutralized with a mixture of baking soda and water.
3. Install the battery vent caps.
4. Charge the battery.
5. Check the battery acid level when the charging cycle is complete. Replenish with distilled water to the bottom of the fill tube. Do not overfill.

8 Error Codes (Only for Type B Platform Controller)

If an error occurs on a machine equipped with a type B platform controller, an error code will appear on the display of the platform controller.

More information about these error codes, their possible cause and solutions can be found in the table below.

| Error Code | Problem | Possible Cause | Solutions |
|------------|---|--|--|
| 01 | Electronic Control Module (ECM) error | No progress in ERPOM | Replace the Electronic Control Module (ECM) |
| 02 | ECM/Platform controller communication error | Cable or platform controller failure | Find the fault of the cable and/or platform controller |
| 03 | Platform DIP switch error | DIP switch setting is not correct | Change the DIP switch setting |
| 12 | Up/Down switch error | Up/Down switch failure | Check the Up/Down switch on the ground control panel |
| 18 | Pothole guard error | Pothole guard switch failure or pothole guard coupling blocked | Check the pothole guard switch and/or remove obstacle |
| 19 | Limit switch error | Limit switch failure or limit switch wire broken | Check the limit switch and/or check limit switch wire |
| 42 | Turning left switch error | Turning left switch failure | Check the turning left switch on the control handle |
| 43 | Turning right switch error | Turning right switch failure | Check the turning right switch on the control handle |
| 46 | Function enable switch error | Function enable switch failure | Check the function enable switch on the control handle |
| 47 | Platform control handle error | Control handle not in median | Recalibrate control handle (potentiometer) |
| 52 | Forward valve coil error | Coil failure or coil disconnected | Check forward valve coil and wiring |
| 53 | Backward valve coil error | Coil failure or coil disconnected | Check backward valve coil and wiring |
| 54 | Raising valve coil error | Coil failure or coil disconnected | Check raising valve coil and wiring |
| 55 | Lowering valve coil error | Coil failure or coil disconnected | Check lowering valve coil and wiring |
| 56 | Right turn valve coil error | Coil failure or coil disconnected | Check right turn valve coil and wiring |
| 57 | Left turn valve coil error | Coil failure or coil disconnected | Check left turn valve coil and wiring |

| | | | |
|----|----------------------------------|--------------------------------------|-----------------------------------|
| 58 | Brake valve coil error | Coil failure or coil disconnected | Check brake valve coil and wiring |
| 59 | Series/parallel valve coil error | DIP switch not correct | Check DIP switch settings |
| 68 | Low battery | Battery uncharged | Recharge the battery |
| 88 | ECM content was cleared | The machine's electrostatic was lost | Change the electrostatic article |

9 Lifting Instructions

Observe and Obey:



- Only qualified personnel should lift the machine.
- Make sure the crane or forklift capacity, loading surfaces and straps or lines are sufficient to withstand the machine weight. See the Specifications or the serial plate for the machine weight.

9.1 Lifting with Forklift

Use the designated holes in the chassis to lift the machine using a forklift.

9.2 Lifting with Crane

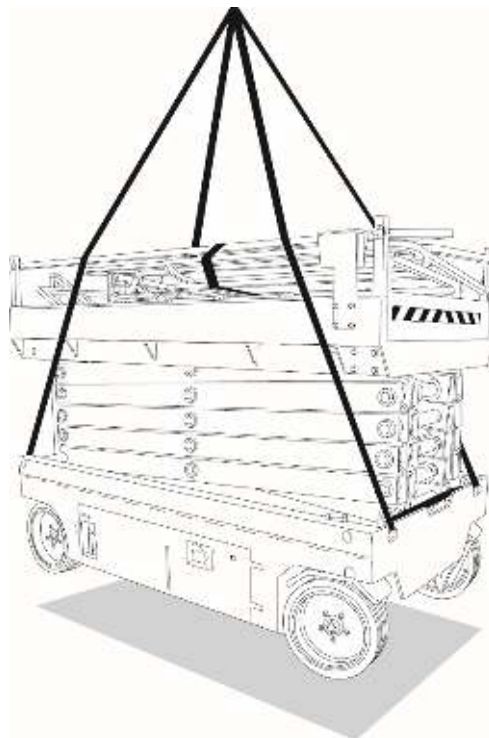

1. Fully lower the platform to the stowed position. Make sure the extension platform, controls and covers are secured. Remove all loose items from the machine.
2. Remove the platform controller from the platform guard rails.

3. Attach the lifting straps or chains to the designated lifting points of the machine.
4. Attach the other end of the lifting straps or chains to the lifting equipment (crane).
5. Adjust the lifting straps or chains to prevent damage to the machine and to keep the machine level while lifting.
6. Lift the machine using the crane.

10 Transport Instructions

Observe and Obey:



- Mantall provides this securement information as a recommendation. Drivers are solely responsible for making sure machines are properly secured and the correct transport vehicle is selected pursuant to localized regulations and their company policy.
- Only qualified aerial lift operators should move the machine on or off the transport vehicle.
- The transport vehicle must be parked on a level surface.
- The transport vehicle must be secured to prevent rolling while the machine is being loaded.
- Be sure the vehicle capacity, loading surfaces and chains or straps are sufficient to withstand the machine weight. See the serial plate for the machine weight.
- If the slope of the transport vehicle bed exceeds the uphill or downhill maximum slope rating, the machine must be loaded and unloaded using a winch as described. See the Specifications section for the slope ratings.

10.1 Towing the Machine (Only for Hydraulically Driven Machines)

1. Chock the wheels to prevent the machine from rolling when releasing the brakes.
2. Make sure the winch line is properly secured to the drive chassis tie points and the path is clear of all obstructions.
3. Push in the brake release knob at the back of the chassis to open the brake valve of the hydraulic drive motors.
4. Pump the brake release pump knob at the back of the chassis to release the brake of the hydraulic drive motors.
5. Free the wheels and tow the machine to the desired position.
6. When the machine is at the desired position, chock the wheels to prevent the machine from rolling.
7. Press and hold the function enable switch on the control handle of the platform controller. Move the control handle off center to reset the brakes of the hydraulic drive motors.

Note: Towing the Mantall machine is not recommended. If the machine must be towed, do not exceed 3,2 km/h.

10.2 Securing the Machine to a Transport Vehicle

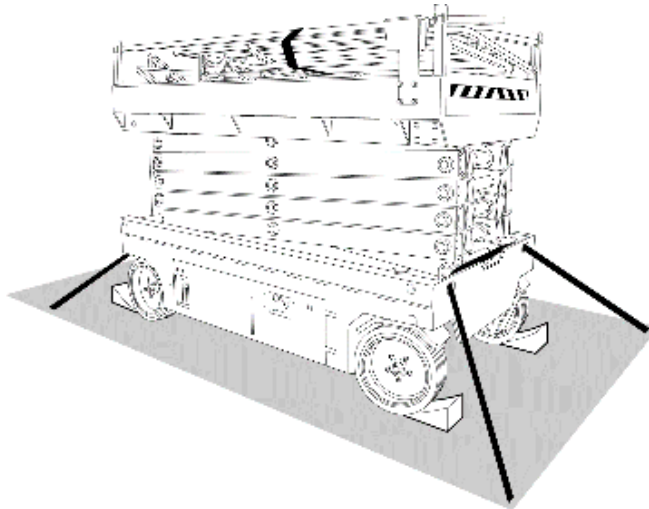

1. Put the machine in the correct position on the transport vehicle.
2. Chock the machine wheels.
3. Retract and secure the extension platform.
4. If necessary, fold down the platform guard rails (see Fold Down of the Platform Guard Rails on page 33) and secure them with straps.
5. Inspect the entire machine for loose or unsecured items.
6. Turn the key switch of the ground control panel to the off position and remove the key before transporting.
7. Use the tie-down points on the chassis to secure the machine to the transport vehicle.
8. Use a minimum of two chains or straps of sufficient load capacity.

11 Maintenance

11.1 Check the Hydraulic Oil Level

Maintaining the hydraulic oil at the proper level is essential for sufficient machine operation. Improper hydraulic oil levels can damage hydraulic components. Daily checks allow the inspector to identify changes in oil level that might indicate hydraulic system issues.

Note: Perform this procedure with the machine level, on a flat surface and the platform in the stowed position.

1. Visually inspect the hydraulic oil level sight gauge located on the side of the hydraulic oil tank.
➤ **Result:** The hydraulic oil level should be between the 2 marks on the sight gauge.
2. Add hydraulic oil if necessary. Do not overfill.

11.2 Add Hydraulic Oil

1. Open the ground control panel side cover.
2. Remove the fill cap from the hydraulic oil tank.
3. Add hydraulic oil until the oil level is between the 2 marks on the hydraulic oil level sight gauge.

Hydraulic oil specifications

Use of hydraulic oil: 32# Anti-wear hydraulic oil.

11.3 Check the Batteries

Proper battery condition is essential for good performance and operational safety. Improper fluid levels or damaged cables and connections can result in component damage and hazardous conditions.



WARNING

Contact with hot or live circuits may result in serious injury or death. Remove all rings, watches and other jewelry.



CAUTION

Batteries contain acid. Avoid spilling or contacting battery acid. Battery acid spills can be neutralized with a mixture of baking soda and water.

1. Put on protective clothing and eye wear.
2. Be sure that the battery cable connections are tight and free of corrosion.
3. Be sure that the battery hold-down brackets are secure.
4. Remove the battery vent caps.
5. Check the battery acid level. If needed, replenish with distilled water to the bottom of the battery fill tube. Do not overfill.
6. Install the vent caps.

Note: Adding terminal protectors and a corrosion preventative sealant will help eliminate corrosion on the battery terminals and cables.

11.4 Lubrication Locations

The following locations can be lubricated:

1. Apply grease to the lubrication nipples of the steering wheels.
2. Slightly lubricate the wear pads at the top ends of the scissors (underside of the platform) with oil.
3. Slightly lubricate the wear pads at the bottom of the scissors (upper side of the chassis) with oil.

Note: Lubrication is not mandatory.

12 Specifications

12.1 Narrow / Compact Models

| Models | XE65N | XE80N | XE80C | XE100C |
|-----------------------------------|---------|---------|---------|---------|
| Working height (max.) | 6,5 m | 7,8 m | 8 m | 10 m |
| Platform height (max.) | 4,5 m | 5,8 m | 6 m | 8 m |
| Outreach | 0,9 m | 0,9 m | 1 m | 1 m |
| Lift capacity | 270 kg | 230 kg | 350 kg | 230 kg |
| Lift capacity (extended platform) | 115 kg | 115 kg | 120 kg | 120 kg |
| Weight | | | | |
| ANSI / CSA Standard | 1164 kg | 1225 kg | 1690 kg | 2000 kg |
| CE / AUS Standard | 1235 kg | 1490 kg | 1830 kg | 2000 kg |
| Platform size: | | | | |
| Length | 1,64 m | 1,64 m | 2,25 m | 2,25 m |
| Extended length | 2,54 m | 2,54 m | 3,2 m | 3,2 m |
| Width | 0,75 m | 0,75 m | 0,8 m | 0,8 m |
| Height | 1,1 m | 1,1 m | 1,1 m | 1,1 m |
| Skirting board height | 0,15 m | 0,15 m | 0,15 m | 0,15 m |
| Stowed machine size: | | | | |
| Length | 1,85 m | 1,85 m | 2,42 m | 2,42 m |
| Length with platform extended | 2,75 m | 2,75 m | 3,4 m | 3,4 m |
| Width | 0,77 m | 0,77 m | 0,8 m | 0,8 m |
| Height (fixed platform) | 1,88 m | 1,98 m | - | - |
| Height (CE) | 2,03 m | 2,13 m | 2,2 m | 2,3 |
| Height with platform folded | 1,69 m | 1,78 m | 1,73 m | 1,86 m |
| Wheelbase | 1,32 m | 1,32 m | 1,85 m | 1,85 m |
| Static wheel load | 643 kg | 678 kg | 975 kg | 998 kg |
| Hydraulic tank capacity | 15 L | 15 L | 15 L | 15 L |
| Vertical/lateral slope rating | 30% | 30% | 30% | 30% |
| Ground clearance | 0,06 m | 0,06 m | 0,1 m | 0,1 m |
| Ground clearance (pothole guards) | 0,02 m | 0,02 m | 0,019 m | 0,019 m |
| Inside rotation radius | 0 m | 0 m | 0 m | 0 m |

| | | | | |
|-------------------------|-----------------------------------|----------|----------|----------|
| Outside rotation radius | 1,56 m | 1,56 m | 2,12 m | 2,12 m |
| Number of people (max.) | 2 | 2 | 2 | 2 |
| Raising time | 13 s | 14 s | 27 s | 28 s |
| Lowering time | 16 s | 17 s | 29 s | 30 s |
| Traction speed | 3,8 km/h | 3,8 km/h | 3,8 km/h | 3,4 km/h |
| Safe speed | 0,7 km/h | 0,7 km/h | 0,7 km/h | 0,7 km/h |
| Vertical tilt angle | | | | |
| ANSI / CSA Standard | 3° | 3° | 3° | 3° |
| CE / AUS Standard | 2° | 2° | 2° | 2° |
| Lateral tilt angle | | | | |
| ANSI / CSA Standard | 2° | 2° | 2° | 2° |
| CE / AUS Standard | 1,5° | 1,5° | 1,5° | 1,5° |
| Power source | 4 x 6 V 225 Ah | | | |
| Tire size | 356 x 114 x 254 mm | | | |
| Drive model | Hydraulic drive or electric drive | | | |

12.2 Wide Models

| Models | XE80W | XE100W | XE120W | XE140W | XE160W |
|-----------------------------------|---------|---------|---------|---------|---------|
| Working height (max.) | 8 m | 10 m | 12 m | 14 m | 16 m |
| Platform height (max.) | 6 m | 8 m | 10 m | 12 m | 14 m |
| Outreach | 1 m | 1 m | 1 m | 1 m | 1 m |
| Lift capacity | 550 kg | 450 kg | 320 kg | 350 kg | 230 kg |
| Lift capacity (extended platform) | 120 kg | 120 kg | 120 kg | 120 kg | 100 kg |
| Weight | | | | | |
| ANSI / CSA Standard | 1855 kg | 2040 kg | 2450 kg | 2690 kg | 3280 kg |
| CE / AUS Standard | 1975 kg | 2520 kg | 2950 kg | 3225 kg | 3400 kg |
| Platform size: | | | | | |
| Length | 2,3 m | 2,3 m | 2,3 m | 2,3 m | 2,3 m |
| Extended length | 3,3 m | 3,3 m | 3,3 m | 3,3 m | 3,3 m |
| Width | 1,15 m | 1,15 m | 1,15 m | 1,15 m | 1,15 m |
| Height | 1,1 m | 1,1 m | 1,1 m | 1,1 m | 1,1 m |
| Skirting board height | 0,172 m | 0,172 m | 0,172 m | 0,172 m | 0,172 m |

| | | | | | |
|-----------------------------------|-----------------------------------|----------|----------|----------|----------|
| Stowed machine size: | | | | | |
| Length | 2,42 m | 2,45 m | 2,45 m | 2,45 m | 2,45 m |
| Length with platform extended | 3,5 m | 3,5 m | 3,5 m | 3,5 m | 3,5 m |
| Width | 1,2 m | 1,2 m | 1,2 m | 1,2 m | 1,2 m |
| Height | 2,12 m | 2,25 m | 2,38 m | 2,51 m | 2,64 m |
| Height with platform folded | 1,56 m | 1,69 m | 1,82 m | 1,95 m | 1,95 m |
| Wheelbase | 1,85 m | 1,85 m | 1,85 m | 1,85 m | 1,85 m |
| Static wheel load | 1075 kg | 1184 kg | 1288 kg | 1448 kg | 1452 kg |
| Hydraulic tank capacity | 15 L | 15 L | 25 L | 25 L | 25 L |
| Vertical/lateral slope rating | 30% | 30% | 30% | 30% | 30% |
| Ground clearance | 0,1 m | 0,1 m | 0,1 m | 0,1 m | 0,1 m |
| Ground clearance (pothole guards) | 0,019 m | 0,019 m | 0,019 m | 0,019 m | 0,019 m |
| Inside rotation radius | 0 m | 0 m | 0 m | 0 m | 0 m |
| Outside rotation radius | 2,3 m | 2,3 m | 2,3 m | 2,3 m | 2,3 m |
| Number of people (max.) | 2 | 2 | 2 | 2 | 2 |
| Raising time | 32 s | 45 s | 55 s | 72 s | 80 s |
| Lowering time | 30 s | 30 s | 37 s | 38 s | 46 s |
| Traction speed | 3,4 km/h | 3,4 km/h | 3,4 km/h | 3,4 km/h | 3,4 km/h |
| Safe speed | 0,7 km/h | 0,7 km/h | 0,7 km/h | 0,7 km/h | 0,7 km/h |
| Vertical tilt angle | | | | | |
| ANSI / CSA Standard | 3° | 3° | 3° | 3° | 3° |
| CE / AUS Standard | 3° | 2° | 2° | 2° | - |
| Lateral tilt angle | | | | | |
| ANSI / CSA Standard | 2° | 2° | 2° | 2° | 2° |
| CE / AUS Standard | 2° | 1,5° | 1,5° | 1,5° | - |
| Power source | 4 x 6 V 225 Ah | | | | |
| Tire size | 406 x 127 x 318 mm | | | | |
| Drive model | Hydraulic drive or electric drive | | | | |